

L02-Model C€

- Permanent magnet motor
- Planetary gearbox
- Acme lead screw or ballscrew (VRS)
- Chrome plated steel push rod
- Permanent grease lubrication
- IP 65, tested according to rule CEI EN 60529
- Working temperature range -10°C +60°C
- Intermittent duty (see performance charts) a 30°C*
- Limit switches on request
- Encoder on request

(*) For any special duty please contact our technical dept.

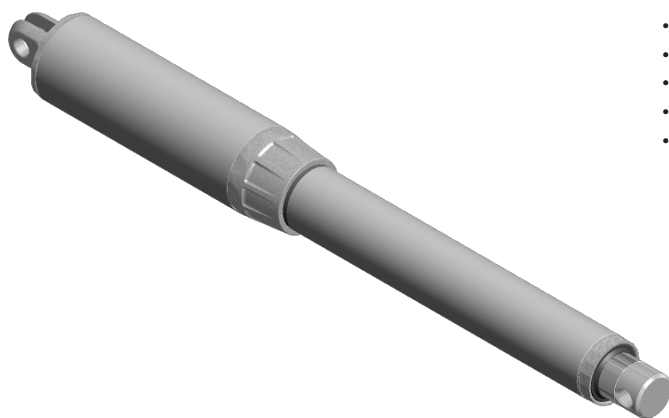

L02 (Vdc)							
Fmax (N)	Speed (mm/s)	Version	Motor size	Motor power (KW)	Motor speed (rpm)	Max Current for Fmax(A) 24Vdc	
* 280	100	M01	36	-	500	4	
* 220	60	M02	36	-	300	1,8	
* 240	40	M03	36	-	300	1,8	
	750	30	M04	36	-	150	2,8
	840	20	M05	36	-	150	2,8
	1600	10	M06	36	-	150	2,6
	2000	5	M07	36	-	80	1,7

L02 (Vdc) ballscrew							
Fmax (N)	Speed (mm/s)	Version	Motor size	Motor power (KW)	Motor speed (rpm)	Max Current for Fmax(A) 24Vdc	
* 1000	42	M01	36	-	500	4	
	1000	25	M02	36	-	300	1,7
	2000	12	M03	36	-	150	2
	2000	6	M04	36	-	80	1,2

* When speed is more than 40 mm/s and/or strokes longer than 350mm, check STROKE SETUP section.

** For 12 Vdc power supply currents are doubled and loads are 20% lower.

BEFORE OPERATING ACTUATOR MAKE SURE YOU READ AND UNDERSTOOD BASIC OPERATIONAL INSTRUCTIONS SHOWN ON USERMANUALS, AVAILABLE FROM WEBSITE.

THIS DOCUMENT DISPLAYS MOST TYPICAL STANDARD FEATURES AND SETUPS: CONTACT OUR OFFICES FOR MORE.

ACTUATOR SHALL NOT COME TO **MECHANICAL STROKE-END**, TO **AVOID FAILURES**.

CONSIDER MECVEL'S LIMITSWITCHES (MODEL L02-F or L02-FCM) OR PUT THEM ON MACHINE/FRAME.



MecVel reserves the right to change products information and/or features without notice; all data contained in this catalogue are purely indicative and not binding for the company.

L02 Version without limitswitches

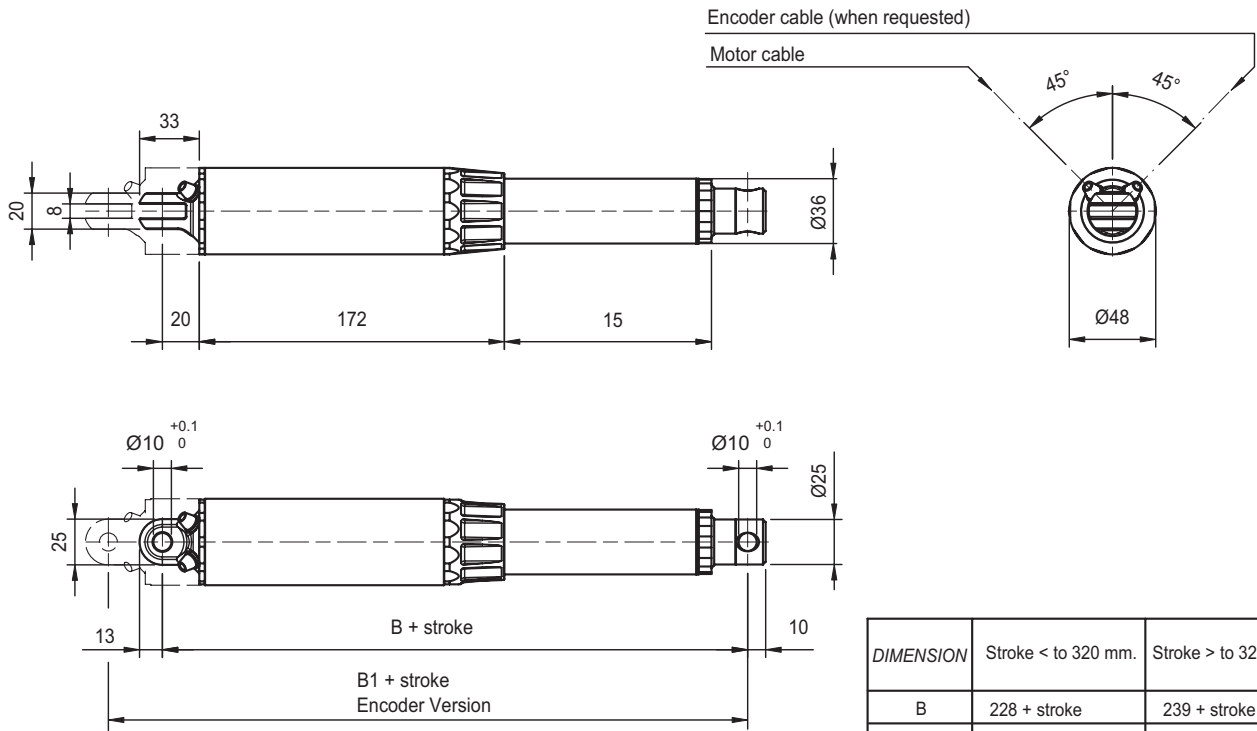

DIMENSION	Stroke < to 320 mm.	Stroke > to 320 mm.
B	228 + stroke	239 + stroke
B1	257 + stroke	268 + stroke

STROKE SETUP: Useful tips for handling stroke and avoid run-on-block collision.

When stroke is more than 350 mm, add 50 mm extra-stroke as guidance, and put corresponding value in ordering-key.

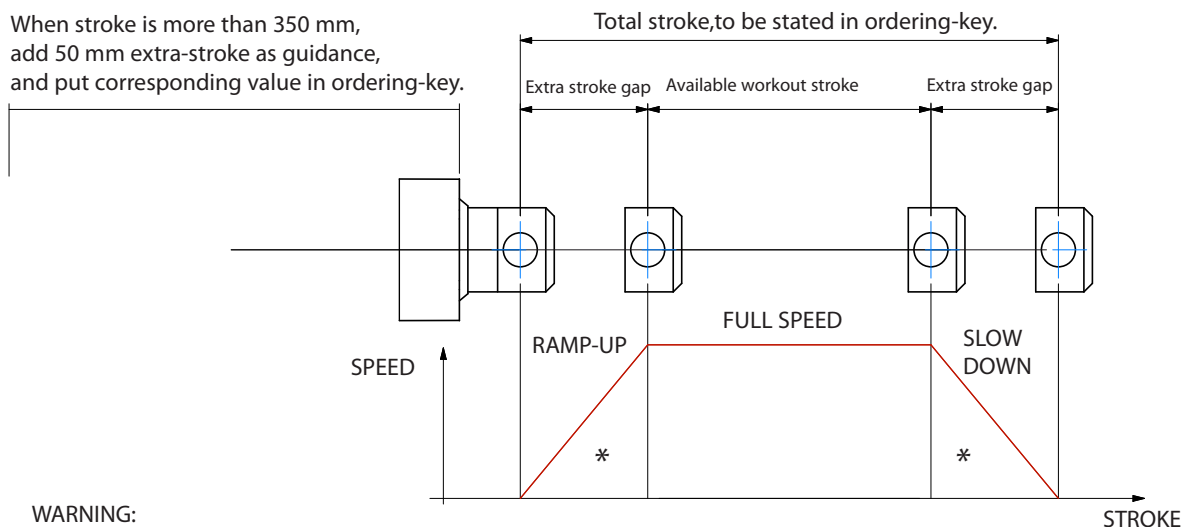

WARNING:
SPEED-TIMING ALONG STROKELENGTH:
 ramps are extremely important with high speed !!! Inverter or PWM drive recommended!
 * The more speed raises the more extra stroke has to raise too.

BUCKLING: When stroke is longer than 500mm, BUCKLING can be a risk: please check mounting with our offices and/or see user-manuals.

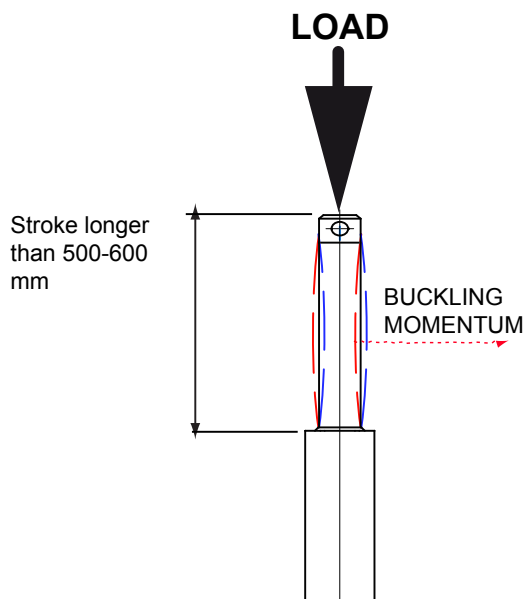

IMPORTANT:
 Long strokes, even if load is low, can generate significant buckling momentums, as sketch slows.
 This happens when actuator is in its all-opened position: that's the reason why we recommend 100 mm extra-stroke.
 Pushtube will have this 100 mm-portion always inside the overtube, improving guidance against buckling.
 For more information on this, contact our office.

ORDERING KEY

L02 / 0250 / M01 / 24 / 2FCM0 / E10 / P1 / A1

MODEL: _____
 L02 L02-FCM L02-VRS

STROKE: _____
 es. 250 mm = 0250
 min 50; with 50 as incremental

VERSION: (Pag. 57) _____
 M00 = Not standard speed

MOTOR: (Pag. ACCESSORIES) _____
 12 = 12 Vdc
 24 = 24 Vdc

LIMIT SWITCHES: (Pag. ACCESSORIES) _____
 None: Leave blank

ENCODER: (Pag. ACCESSORIES) _____
 E10: Encoder 1 channel 4 ppr NPN (open Collector)

REAR END: _____
 P1 = Yoke (standard)
 P2 = Special (provide drawing)

FRONT END: _____
 A1 = Eyelet (Std pag.58)
 A3 = Yoke + Clip
 A4 = Rod end
 A7 = M10 male

NOTE: COMPLETE THE ORDERING KEY ADDING THE OPTIONS YOU CAN FIND IN THE "ACCESSORIES AND OPTIONS" SECTION

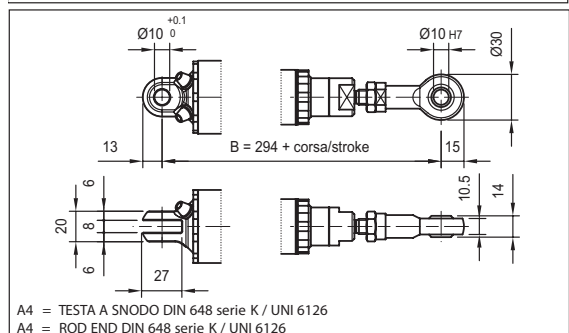
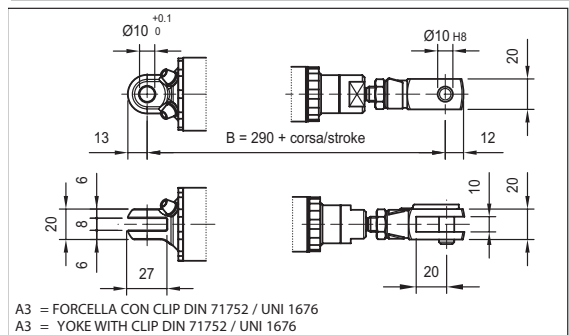
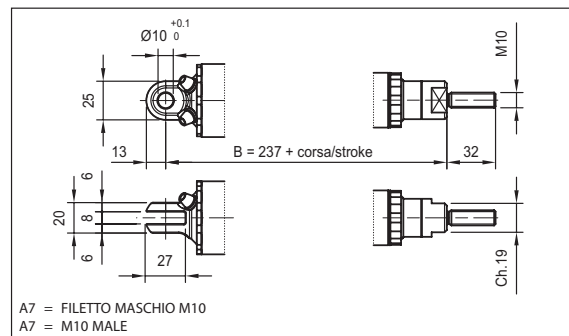
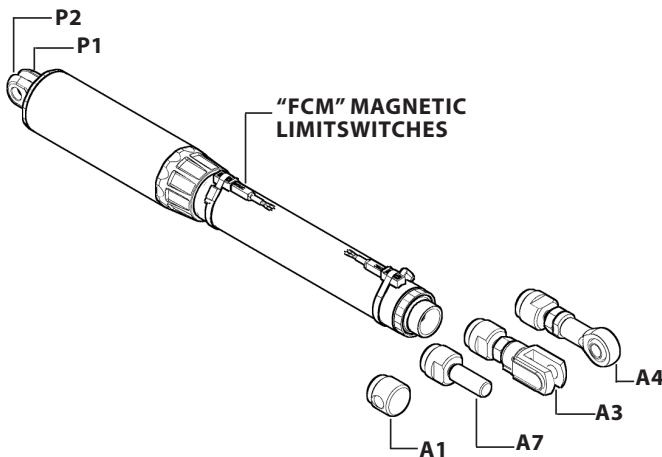

Note: "B" dimension changes according to model
Note: With encoder, dimension "B" is 30 mm longer
 L02 = See pictures
 L02 stroke > 320 mm = + 11 mm
 L02-FCM = + 34 mm
 L02-FCM stroke > 320 mm = + 45 mm
 with safety nut "G" = + 30 mm
 L02-VRS = + 40 mm
 Bellows + 20mm (no for versions FCM)